





LIGHT REPLACEMENT MADE EASY

Replacement Guide



 Spa Electric[®]

spaelectrics.com |    

retro[®]

REPLACEMENT LED POOL LIGHT

WHY CHOOSE SPA ELECTRICS?

The underwater lighting specialists



Over **48** years of product knowledge, industry experience, and technical innovation.



We are the leading manufacturer of premium LED lighting for the swimming pool and spa industry.



You can rely on us, we back our customers with friendly service, and valuable product training.



UL Listed meeting nationally recognised standards for sustainability and safety.

We are always here to help

If you require any assistance, please call us on +1 800 708 5545 or email techusa@spaelectrics.com

INDEX

PRODUCT OVERVIEW	4
ADAPTOR KITS AND SPARE PARTS	7
PRE-INSTALLATION CHECK	8
R10 RETRO FITS	10
R10 RETRO FIT INSTRUCTIONS	13
R8 RETRO INSTRUCTIONS	16
R6 RETRO FITS	18
R6 RETRO FIT INSTRUCTIONS	20
N1 RETRO FITS	25
N1 RETRO FIT INSTRUCTIONS	26
CABLE INSTALLATION	27
LED LIGHT OPERATION	28
LED LIGHT OPERATION ADVANCED	29
LED LIGHT COMPATIBLE CONTROLLERS	31
LITYARD INSTALLATION	32
QUICK SET UP JANDY CONTROLLER	34
QUICK SET UP INTELLIBRITE CONTROLLER	35
SERVICE & WARRANTY	36

PRODUCT OVERVIEW

R10 SERIES 10" REPLACEMENT LIGHTS

LIGHTS & MOUNTING KIT CHOOSE YOUR LIGHT OPTION, THEN UNIVERSAL ADAPTOR & RIM COLOR

Pool Type	LED Option	Rim Color	Product Code
CONCRETE & VINYL POOLS 1x Retro 10" (R10) Light + 10" Niche Adaptor + Plug Seal Assembly Kit + Rim	Multi Plus	White	R10C L12 R1 WMP
		Grey	R10C L12 R1 GMP
	Blue	White	R10C L12 R1 WBL
		Grey	R10C L12 R1 GBL
	White 4000k	White	R10C L12 R1 WW4
		Grey	R10C L12 R1 GW4
	White 3000k	White	R10C L12 R1 WW3
		Grey	R10C L12 R1 GW3

REPLACEMENT LIGHTS INCLUDES 1X 10" LIGHT

Pool Type	LED Option	Product Code
CONCRETE & VINYL POOLS	1x Retro 10" (R10) Multi Plus Light	R10 L12 L0 MP
	1x Retro 10" (R10) Blue Light	R10 L12 L0 BL
	1x Retro 10" (R10) White 4K Light	R10 L12 L0 W3
	1x Retro 10" (R10) White 3K Light	R10 L12 L0 W4

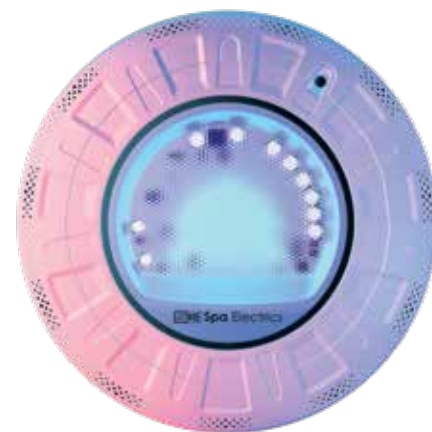

Retro R10

R6 SERIES 6" REPLACEMENT LIGHTS

LIGHTS & MOUNTING KIT CHOOSE YOUR LIGHT OPTION, THEN UNIVERSAL ADAPTOR & RIM COLOR

Pool Type	LED Option	Rim Color	Product Code
CONCRETE & VINYL POOLS 1x Retro 6" (R6) Light + 6" Niche Adaptor + Plug Seal Assembly + Rim	Multi Plus	White	R6C L12 R1 WMP
		Grey	R6C L12 R1 GMP

REPLACEMENT LIGHTS INCLUDES 1X 6" LIGHT

Pool Type	LED Option	Product Code
CONCRETE & VINYL POOLS	1x Argon 3" Multi Plus Light	N3 L12 L0 MP



Retro R6

PRODUCT OVERVIEW

R8 SERIES 8" REPLACEMENT LIGHTS

LIGHTS & MOUNTING KIT CHOOSE YOUR LIGHT OPTION, THEN UNIVERSAL ADAPTOR & RIM COLOR

Pool Type	LED Option	Rim Color	Product Code
CONCRETE POOLS 1x Retro 8" (R8) Light + 8" Niche Adaptor + Plug Seal Assembly Kit + Rim	Multi Plus	White	R8C L12 R1 WMP
		Grey	R8C L12 R1 GMP
	Blue	White	R8C L12 R1 WBL
		Grey	R8C L12 R1 GBL
	White 4000k	White	R8C L12 R1 WW4
		Grey	R8C L12 R1 GW4
	White 3000k	White	R8C L12 R1 WW3
		Grey	R8C L12 R1 GW3

REPLACEMENT LIGHTS INCLUDES 1X 10" LIGHT

Pool Type	LED Option	Product Code
CONCRETE POOLS	1X Retro 10" (R10) Multi Plus Light	R10 L12 L0 MP
	1X Retro 10" (R10) Blue Light	R10 L12 L0 BL
	1X Retro 10" (R10) White 4K Light	R10 L12 L0 W4
	1X Retro 10" (R10) White 3K Light	R10 L12 L0 W3



Retro R8

COMING SPRING 24!

N1 SERIES 1.5" THREADED REPLACEMENT LIGHTS

LIGHTS & MOUNTING KIT CHOOSE YOUR LIGHT OPTION, THEN UNIVERSAL ADAPTOR & RIM COLOR

Pool Type	LED Option	Rim Color	Product Code
CONCRETE & VINYL POOLS X1 Argon Light + Adaptor Plate + Plug Kit	Multi Plus	Clear	N1 L12 R1 CMP

REPLACEMENT LIGHTS INCLUDES 1X 6" LIGHT

Pool Type	LED Option	Rim Color	Product Code
CONCRETE & VINYL POOLS 1x Argon Light + Clear Rim	Multi Plus	Clear	N3 L12 L0 MP



Retro N1

PRODUCT OVERVIEW



QUANTUM

REPLACEMENT LIGHTS

Pool Type	LED Option	Product Code
CONCRETE POOLS	1x Quantum 6" Multi Plus Light	Q6 L12 L0 CMP
	1x Quantum 6" Blue Light	Q6 L12 L0 CBL
	1x Quantum 6" White 4000K Light	Q6 L12 L0 CW4
	1x Quantum 6" Turtle Red Light	Q6 L12 L0 CRD



Quantum 6" Light



atom

REPLACEMENT LIGHTS

Pool Type	LED Option	Product Code
CONCRETE, VINYL & FIBREGLASS POOLS	1x Atom 3" Multi Plus Light	A3 L12 L0 CMP
	1x Atom 3" Blue Light	A3 L12 L0 CBL
	1x Atom 3" White 4000K Light	A3 L12 L0 CW4
	1x Atom 3" Turtle Red Light	A3 L12 L0 CRD



Atom 3" Light



ARGON

REPLACEMENT LIGHTS

Pool Type	LED Option	Product Code
VINYL & FIBREGLASS POOLS	1x Argon 3" Multi Plus Light	N3 L12 L0 MP



Retro N3

ADAPTOR KITS AND SPARE PARTS

In the majority of retro fit installations, additional adaptor kits are not required. However, there is a small handful of lights that do require the addition of an adaptor kit to complete a seamless installation.

In the case that an adaptor kit is required, it will be listed throughout this booklet to ensure you order all necessary parts to complete the retro fit.

ACCESSORIES		
Pool Type	Accessory	Product Code
CONCRETE & VINYL POOLS	Retro 10" (R10) Universal Adaptor - White	R10C 008 WH
	Retro 10" (R10) Universal Adaptor - Grey	R10C 008 GY
	Retro 10" (R10) Rim White	R10 004 WH
	Retro 10" (R10) Rim Grey	R10 004 GY
	Retro 10" (R10) Concrete Plug Cover	R10 001
	Retro 10" (R10) Concrete Plug Top Kit	R10 003
	Retro 10" (R10) Concrete Adaptor Cam Lock Kit	R10C 006
	Retro 10" (R10) Concrete Adaptor Hook + Mounting Screws	R10 007
	Retro 10" (R10) Vinyl Trim Kit 3x Dress Rings Grey	R10V 0021 GY
	Retro 10" (R10) Vinyl Trim Kit 3x Dress Rings White	R10V 0021 WH
	Retro 10" (R10) - 100ft 12AWG Power Cord	R10 12AWG 100 US
	Retro 10" (R10) - 150ft 12AWG Power Cord	R10 12AWG 150 US
	Retro 6" (R6) Adaptor Plate White	R6C 008 WH
	Retro 6" (R6) Adaptor Plate Grey	R6C 008 GY
	Retro 6" (R6) Q500 Cam Lock Kit	R6C 006 Q5
	Retro 6" (R6) Vinyl Trim Kit - x3 Dress Rings White	R6V 0021 WH
	Retro 6" (R6) Vinyl Trim Kit - x3 Dress Rings Grey	R6V 0021 GY
	N1 Adaptor Kit (no Light)	N1 005
	Plug Top Kit	N3 003
	Clear Rim	N1 004 CL
	Retro 8" (R8) - Concrete Adaptor Plate (White)	R8C 008 WH
	Retro 8" (R8) - Concrete Adaptor Plate (Grey)	R8C 008 GY
	Retro 8" (R8) Standard Cam Lock Kit	R8C 006



R10C 008 WH



R10 004

R10 003



R10C 006

R10 007



R6C 008

PRE-INSTALLATION CHECK

1. CHECK POWER SUPPLY

A 12V AC Transformer **MUST** be installed between the 120V power supply and pool light. Do **NOT** continue installation if directly connected to 120V power.

DO **NOT** CONTINUE INSTALLATION IF DIRECTLY CONNECTED TO 120V POWER.

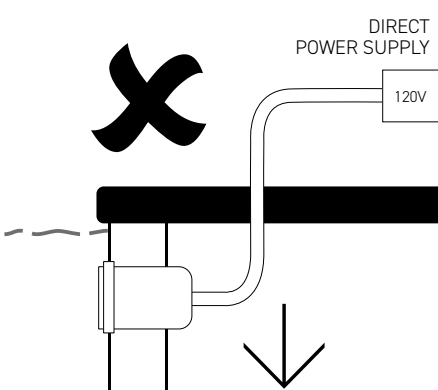

IF THERE IS AN EXISTING TRANSFORMER, CHECK THAT IT MEETS THE SPECIFICATIONS LISTED BELOW IN STEP 2.

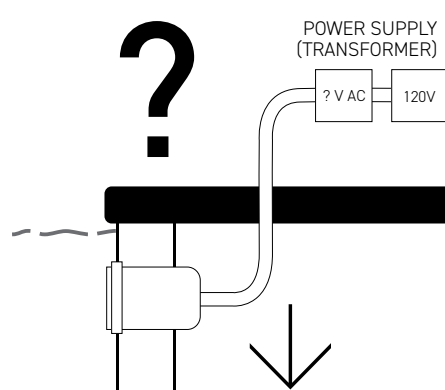

2. ADD A TRANSFORMER

TRANSFORMER REQUIRED SPECIFICATION:

- UL Listed Isolating Low Voltage power supply, evaluated for swimming pool use
- Installed as per current NEC wiring rules
- 12-14V AC output
- Minimum Wattage requirement per light. See Step 2a.
- In good working order

TRANSFORMER MUST **NOT** BE:

- DC or 'LED Driver'
- Electronic or Switch mode
- Weather damaged or in otherwise poor condition.

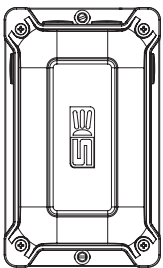

Spa Electrics recommends “**LVX**” safety transformers or LITYARD Control System for use with **Retro Universal** lights.

Available Models:

- LVX50
- LVX50P
- LVX100
- LVX100P
- LITY2RFH

2a. WATTAGE REQUIREMENT



R6, N1: 15W PER LIGHT

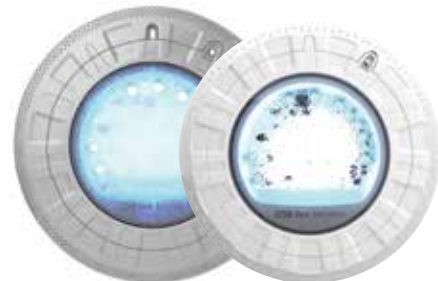

R10, R8: 45W PER LIGHT

3. CHECK CABLE THICKNESS

Retro Universal can fit cables from 9/32" (7mm) up to 9/16" (14mm) diameter



4. CHECK BONDING

Ensure bonding is secure at the back of the niche.

DO NOT CUT the bonding cable. **DO NOT DISTURB** the bonding cable when working with the plug cable.

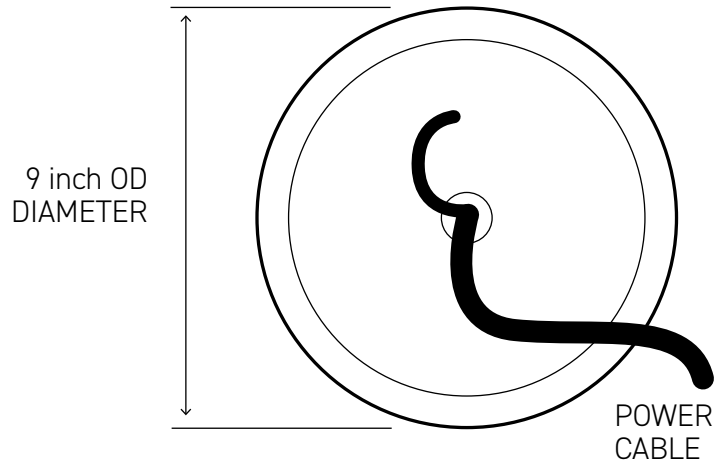
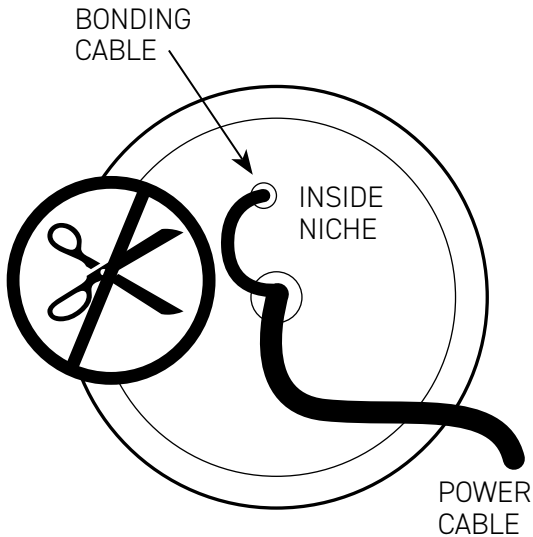

5. CHECK NICHE DIAMETER

Retro Universal lights are designed to work with various diameter niches. Please refer to the table below for niche/pipe diameter and the recommended Retro Fit options.

NICHE DIAMETER AND RETRO-FIT OPTION	
Niche/Pipe Diameter (inch)	Recommended Retro-Fit
9.0" – 9.6"	R10
7.4" – 8.1"	R8
4.6" – 5.2"	R6 with standard cam locks
5.8" – 6.6"	R6 with Q500 cam locks (sold separately)
1.5" thread fitting	N1

R10 RETRO FITS

R10 RETRO-FIT WITH STANDARD R10 BRACKET

Light Model	Dimension	Spare Part
IntelliBrite® 5G Color and White LED Pool Lights	10"	N/A
Intellibrite® Architectural Series	10"	N/A
Pentair 78210300 Stainless Steel Niches	10"	N/A
Pentair 79206700 Plastic Niches	10"	N/A
Jandy Large Stainless Steel ProNiche SSNICLRG1R	10"	N/A
Jandy® Large White Incandescent Light	10" diameter 5.01" depth	N/A



R10 RETRO FITS (CONTINUED)

R10 RETRO-FIT WITH STANDARD R10 BRACKET		
Light Model	Dimension	Spare Part
Jandy® Commercial Large White LED Light	10.04" diameter 3.24" depth	N/A
Pentair Amerlite® Underwater Incandescent Light	10.12" diameter 7.72" depth	
Large Plastic Niche, Gunite Pool Light PLNICLRG	9.85"	
Hayward Large Niche-Gun/Con SS 1/2 REA		
Hayward DuraNiche SPX9607UC/SP0607U (Vinyl)		R10 Vinyl Dress Ring 2
Hayward Plastic Niche – Vinyl Pool SP0508A (Vinyl)		R10 Vinyl Dress Ring 2
Pentair Stainless Steel Niche 78232500 (Vinyl)		R10 Vinyl Dress Ring 3
Pentair Quick Niche ASY 620004 (Vinyl)		R10 Vinyl Dress Ring 1



R10 RETRO FITS (CONTINUED)

R10 RETRO-FIT WITH STANDARD R10 BRACKET

Light Model	Dimension	Spare Part
Hayward ColorLogic 4.0 LED Pool & Spa Lights	N/A	N/A
J&J Electronics INC. XG-W Series SwimQuip Version Light fits into existing large niches with similar mounting dimensions to Jandy PLNICLRG	N/A	N/A
Pooltone™ Standard 16 Color Led Pool Light	10"	N/A
Jacuzzi Full Moon Pool Light	10 ½"	N/A
Hayward AstroLite Pool Lighting	N/A	N/A
S.R. Smith kēlo®XL Light fits into existing large niches with similar mounting dimensions to Jandy PLNICLRG	10"	12V

R10H RETRO FIT WITH R10H ADAPTOR

Light Model	Dimension	Spare Part
Hayward Universal ColorLogic® and CrystaLogic™ (Shallow Niche)	N/A	R10H Adapter



R10 RETRO FIT INSTRUCTIONS



ATTACH NICHE ADAPTOR

1. ATTACH CAMS TO NICHE ADAPTOR

CLIP IN ALL THREE CAMLOCK PIVOT ARMS INTO THE NICHE ADAPTOR BODY. ENSURE RED WASHER IS ASSEMBLED TO SCREW. FASTEN THE M6 X 40P CAMLOCK SCREWS IN THROUGH THE NICHE ADAPTOR BODY AND CAMLOCK PIVOT ARM.

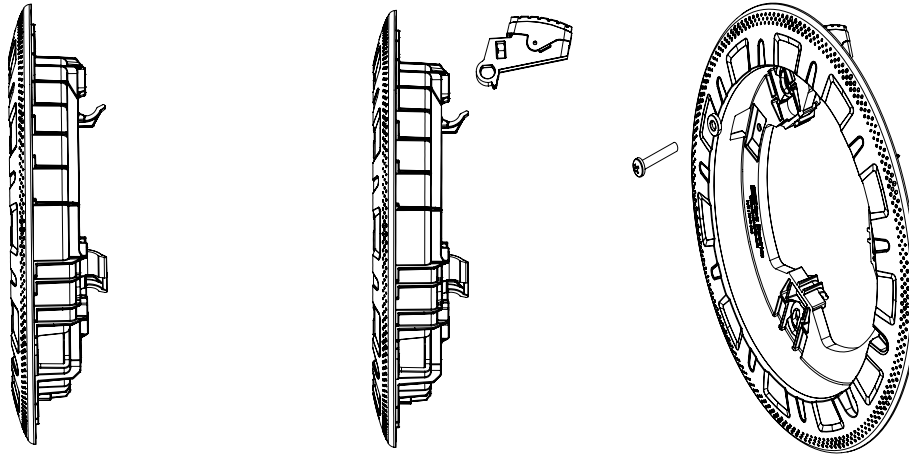

2. INSERT NICHE ADAPTOR

FEED THE CABLE THROUGH THE NICHE ADAPTOR

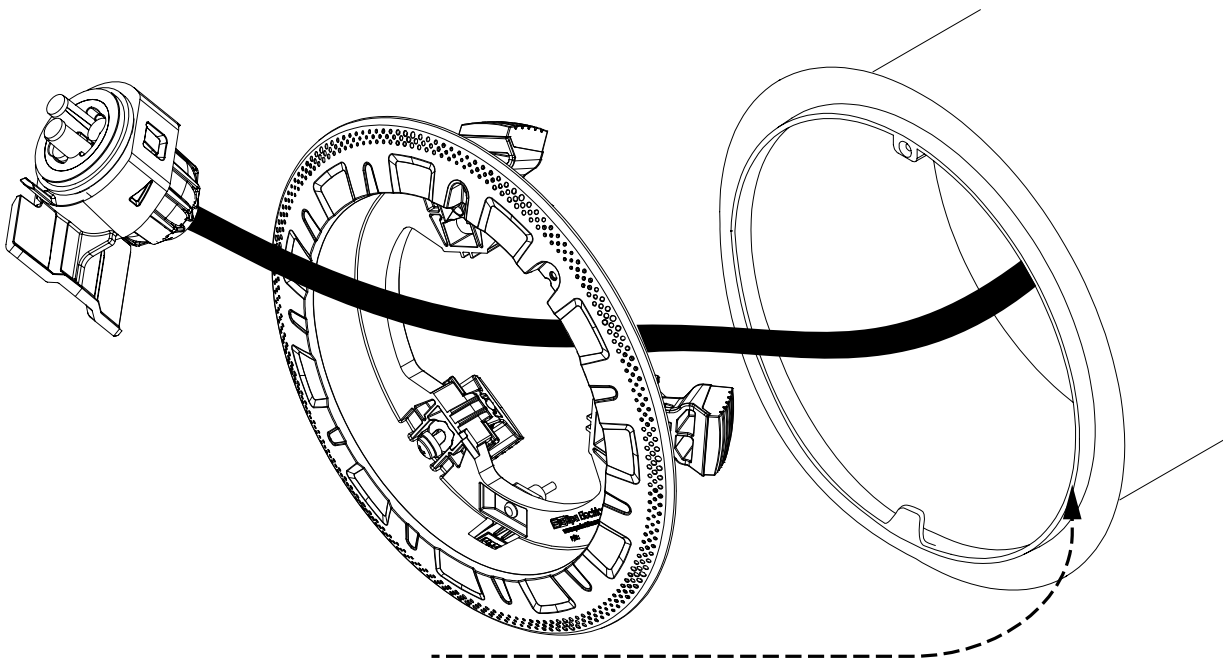

R10 RETRO FIT INSTRUCTIONS (CONT.)

NICHE TAB & SCREW FITTING

3. IF NICHE TAB & SCREW FITTING IS INTACT:

CENTRE NICHE ADAPTOR INTO NICHE, SO THE SCREW HOLE IS AT 12 O'CLOCK, OR LINES UP WITH THE SCREW FITTING ON NICHE

ENSURE THE CAM LOCKS GO INTO THE NICHE EASILY

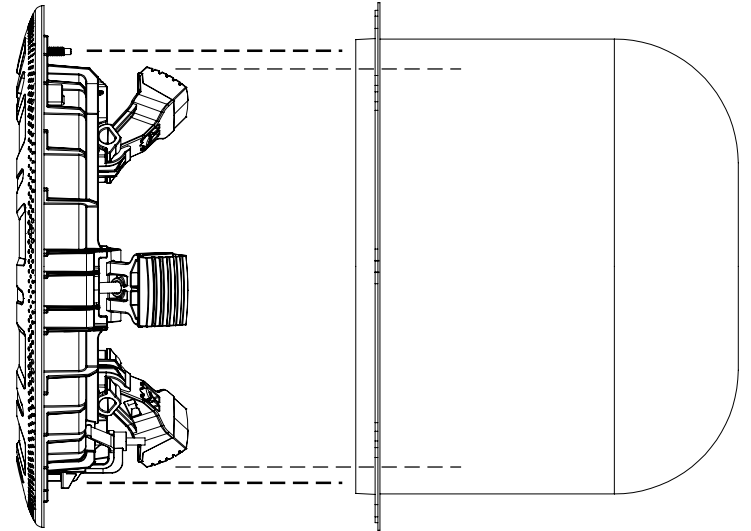
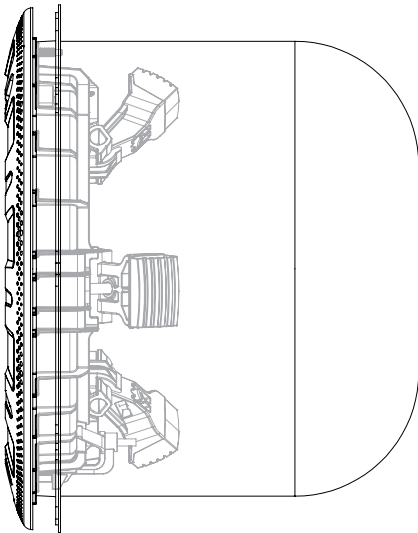

PUSH THE NICHE ADAPTOR INTO THE WALL SO IT SITS FLUSH AND IS FULLY INSERTED INTO THE NICHE

TIGHTEN THE THREE CAM LOCK SCREWS EQUALLY AND IN ROTATION, AS SHOWN, BY HAND UNTIL YOU FEEL THE NICHE ADAPTOR IS SECURE IN PLACE

DO NOT OVERTIGHTEN.

CHECK FOR SECURE FITTING, THE NICHE ADAPTOR SHOULD BE FIRM AND NOT ABLE TO MOVE EASILY BY HAND

GO TO **SECTION C: CONNECT LUMINAIRE**

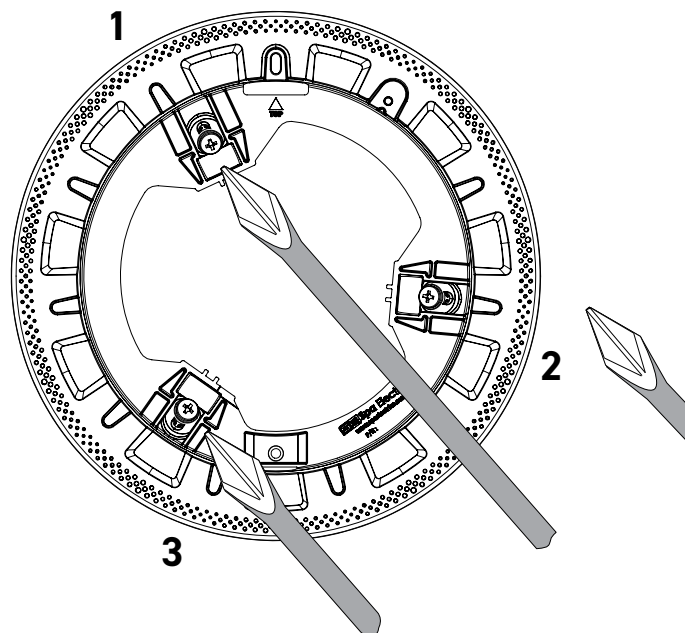

AS THE CAM LOCK SCREWS TIGHTEN, THE CAM LOCKS WILL MOVE IN AND UP, PULLING THE NICHE ADAPTOR FIRMLY INTO THE NICHE

MINIMUM CAM LOCK POSITION (LOOSE)

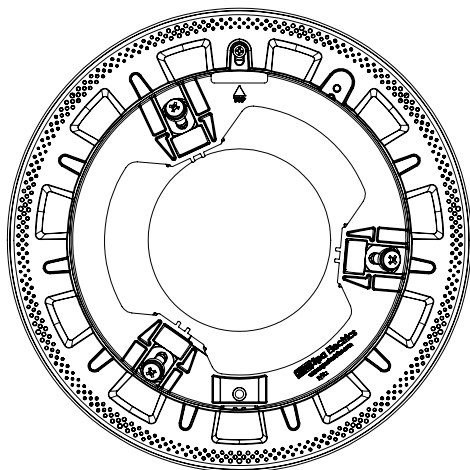

TIGHTEN SCREWS TO PULL NICHE ADAPTOR INTO NICHE

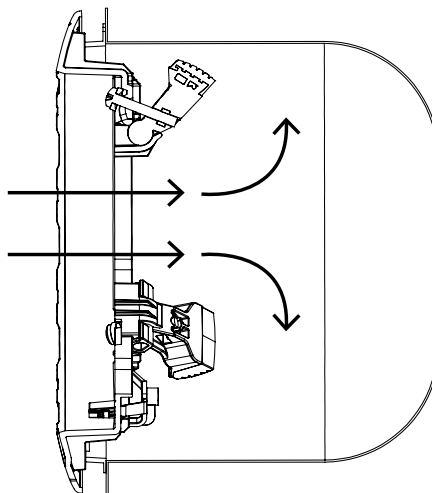

MAXIMUM CAM LOCK POSITION (TIGHT)

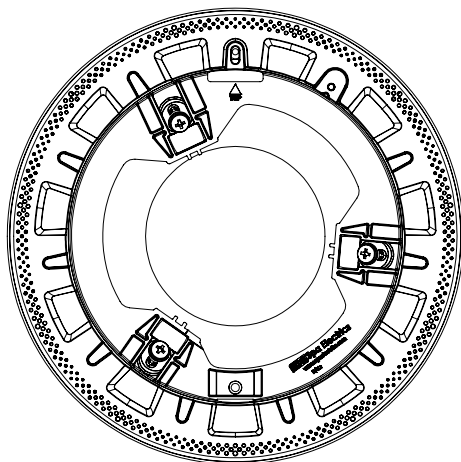

WHEN ALL CAM LOCKS ARE SCREWED TIGHT, THE CAM LOCKS SIT TIGHT AGAINST THE INSIDE OF THE NICHE, AND THE NICHE ADAPTOR IS PULLED FURTHER INTO THE WALL

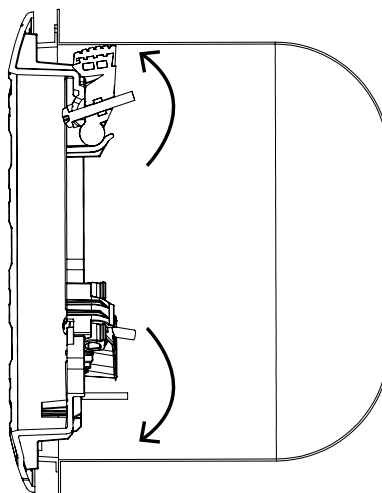

R8 RETRO INSTRUCTIONS

INSERT NICHE ADAPTOR

1. FEED THE CABLE THROUGH THE NICHE ADAPTOR

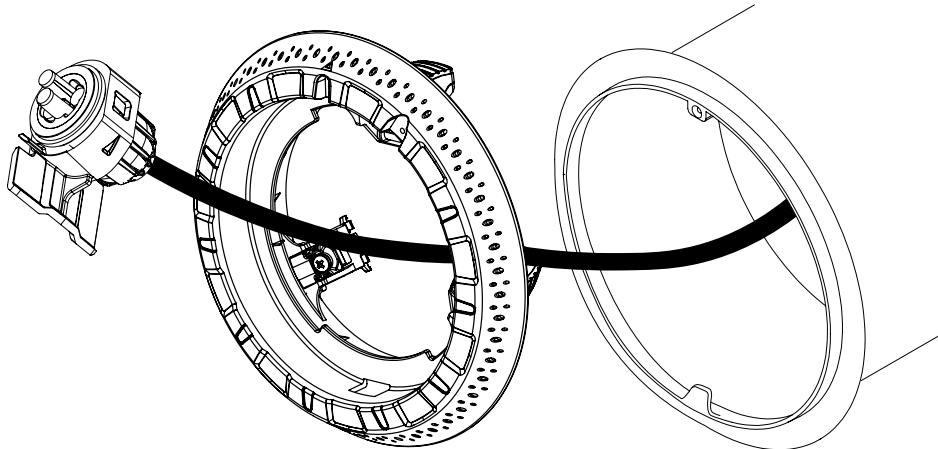

2. CENTRE NICHE ADAPTOR INTO NICHE, SO THE ARROW ON THE ADAPTOR IS POINTING UP

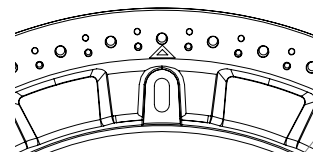

3. ENSURE THE CAM LOCKS GO INTO THE NICHE EASILY

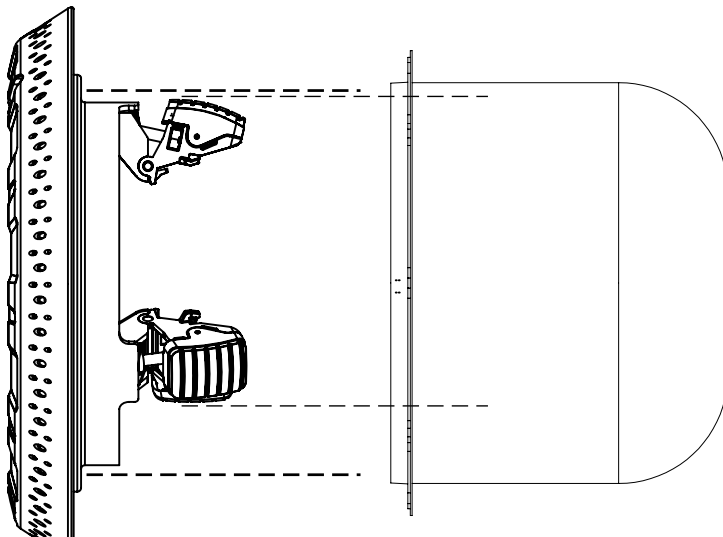

4. PUSH THE NICHE ADAPTOR INTO THE WALL SO IT SITS FLUSH AND IS FULLY INSERTED INTO THE NICHE

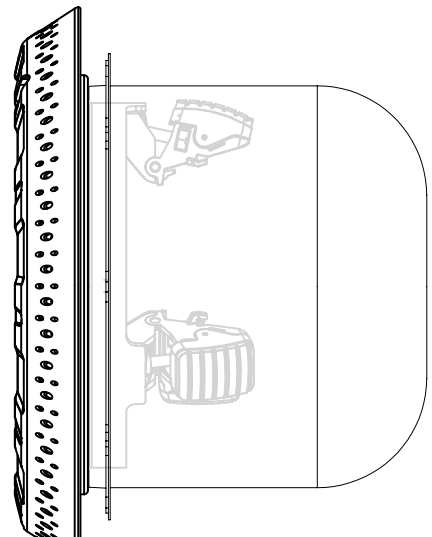

ADJUST AND SECURE NICHE ADAPTOR

TIGHTEN THE THREE CAM LOCK SCREWS EQUALLY AND IN ROTATION, AS SHOWN, BY HAND UNTIL YOU FEEL THE NICHE ADAPTOR IS SECURE IN PLACE

DO NOT OVERTIGHTEN.

CHECK FOR SECURE FITTING, THE NICHE ADAPTOR SHOULD BE FIRM AND NOT ABLE TO MOVE EASILY BY HAND

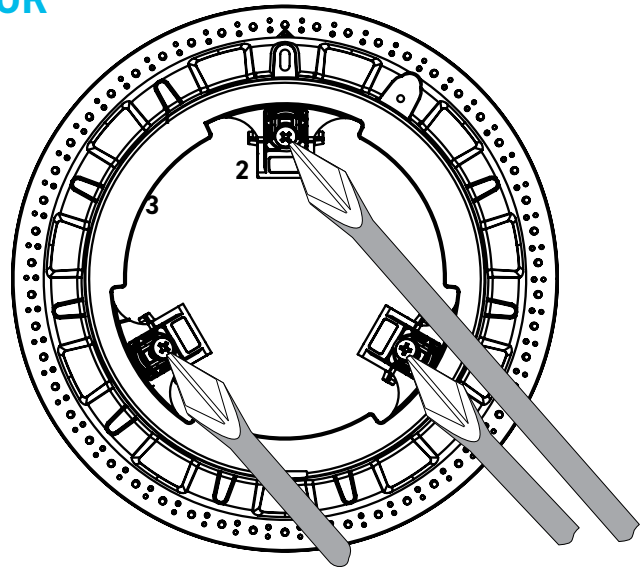

AS THE CAM LOCK SCREWS TIGHTEN, THE CAM LOCKS WILL MOVE IN AND UP, PULLING THE NICHE ADAPTOR FIRMLY INTO THE NICHE

THE ADJUSTMENT RANGE OF THE CAMS ACHIEVE P.C.D. 7 1/2" - 8 1/4" (190-210mm) (APPROX.)

MINIMUM
CAM LOCK
POSITION
(LOOSE)

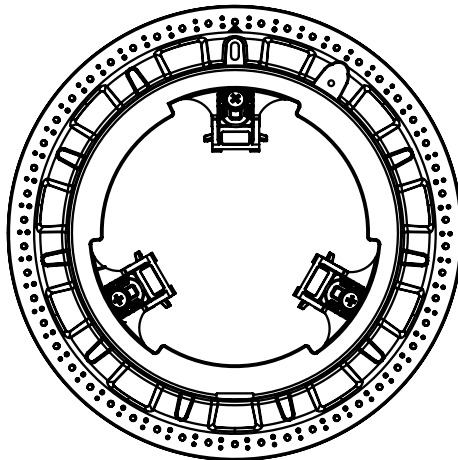

TIGHTEN
SCREWS
TO PULL
NICHE
ADAPTOR
INTO NICHE

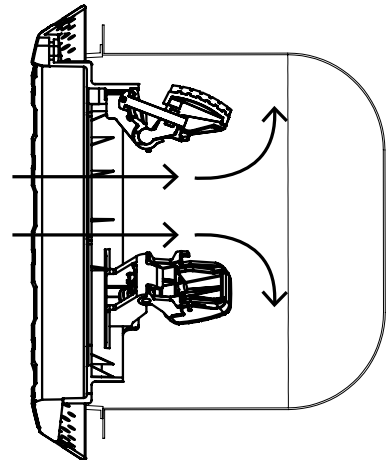

MAXIMUM
CAM LOCK
POSITION
(TIGHT)

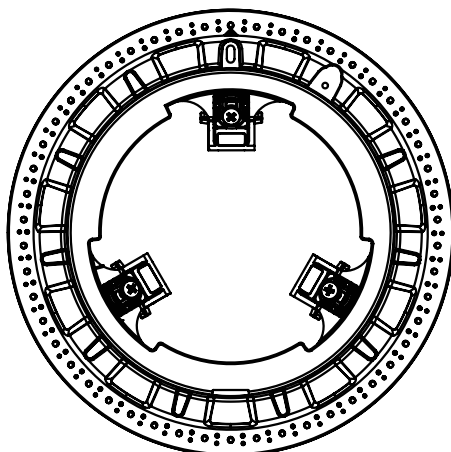

WHEN ALL CAM
LOCKS ARE
SCREWED TIGHT,
THE CAM LOCKS
SIT TIGHT AGAINST
THE
INSIDE OF THE
NICHE, AND THE
NICHE ADAPTOR IS
PULLED FURTHER
INTO THE WALL

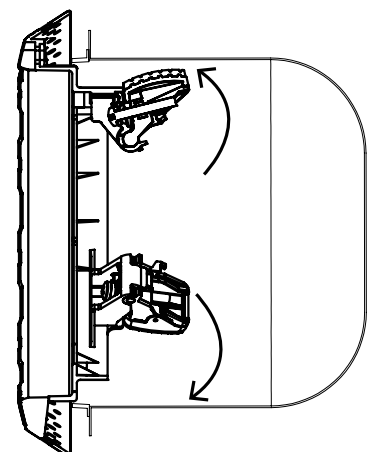

R6 RETRO FITS

R6 WITH STANDARD R6 BRACKET RETRO FITS

Light Model	Dimension
Pentair Plastic Niche (Small) 79206600 – Verified fits with red (standard) feet only	5.3"
Jandy ProNiche PL – Small, PLNICSM – Verified fits with red (standard) feet only	5.2"
Hayward ULC Series Underwater Small Lighting Niche (Unverified)	6.5"
Hayward DuraNiche™ SP0607U, SP0608U and SP0601U SP0601U – Verified fits with red feet only 4.6" (literature says 4.8")	4.6"
SP0608H – Verified fits with red feet only 5.3" (will be a gap due to internal tab & mounting bracket)	5.3"
Hayward AstroLite™ II Series Spa Lighting SP0590 series (unverified)	5 3/4" (outside diameter of face rim)
Pentair – Sta-Rite SwimQuip Pool Light P/N 78244200 & 78241202 i). P/N 7824200 ii). P/N 78241202	4.8"



R6 RETRO FITS (CONTINUED)

R6 WITH STANDARD R6 BRACKET RETRO FITS

Light Model

Dimension

IntelliBrite® 5G Color and White LED Pool Lights (unverified) 6"

Jacuzzi Q500 Underwater Pool Light (unverified)

Unknown

Blue Square Spectrum 360

N/A

R6 WITH STANDARD R6 BRACKET RETRO FITS

Light Model

Dimension

Spare Part

Jacuzzi Q500 Underwater Pool Light (unverified)

N/A

Q500 Cam's



R6 RETRO FIT INSTRUCTIONS

ATTACH NICHE ADAPTOR

CHECK QUALITY OF NICHE:

ENSURE NICHE TAB AND SCREW FITTING IS INTACT, NOT DAMAGED OR CORRODED AND FIT FOR PURPOSE.

IF THE NICHE TAB AND SCREW FITTING IS INTACT: THEN FOLLOW **3A STEPS** IF ANY PARTS ARE BROKEN OR NOT SERVICEABLE, FOLLOW **3B STEPS**.

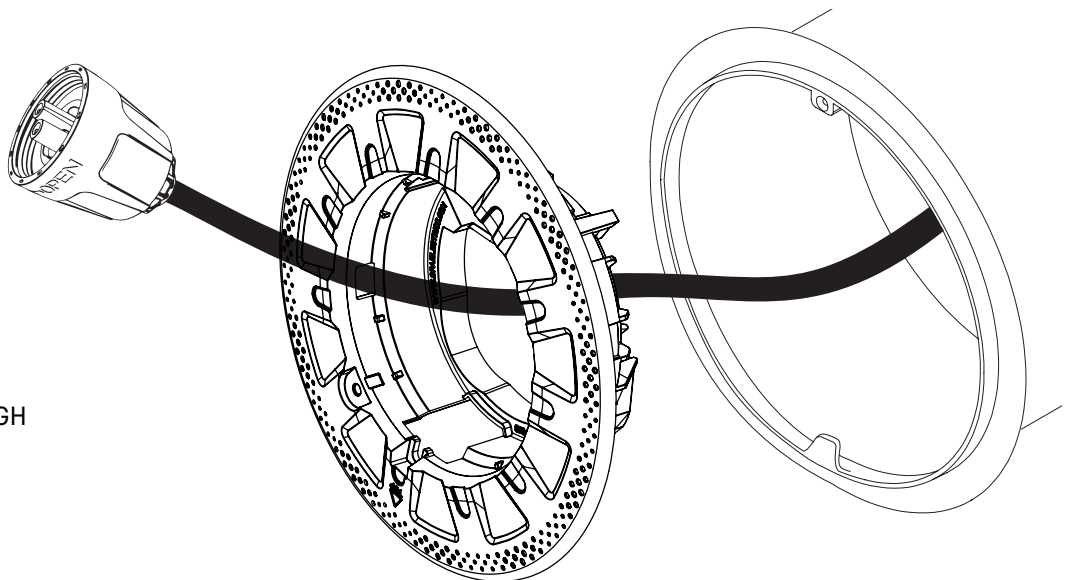

INSERT NICHE ADAPTOR:

FEED THE CABLE THROUGH
THE NICHE ADAPTOR

 [Click here for full instructions](#)

NICHE TAB & SCREW FITTING

IF NICHE TAB & SCREW FITTING IS INTACT:

LINE UP NICHE ADAPTOR TO NICHE
WITH SCREW HOLE AT 12 O'CLOCK

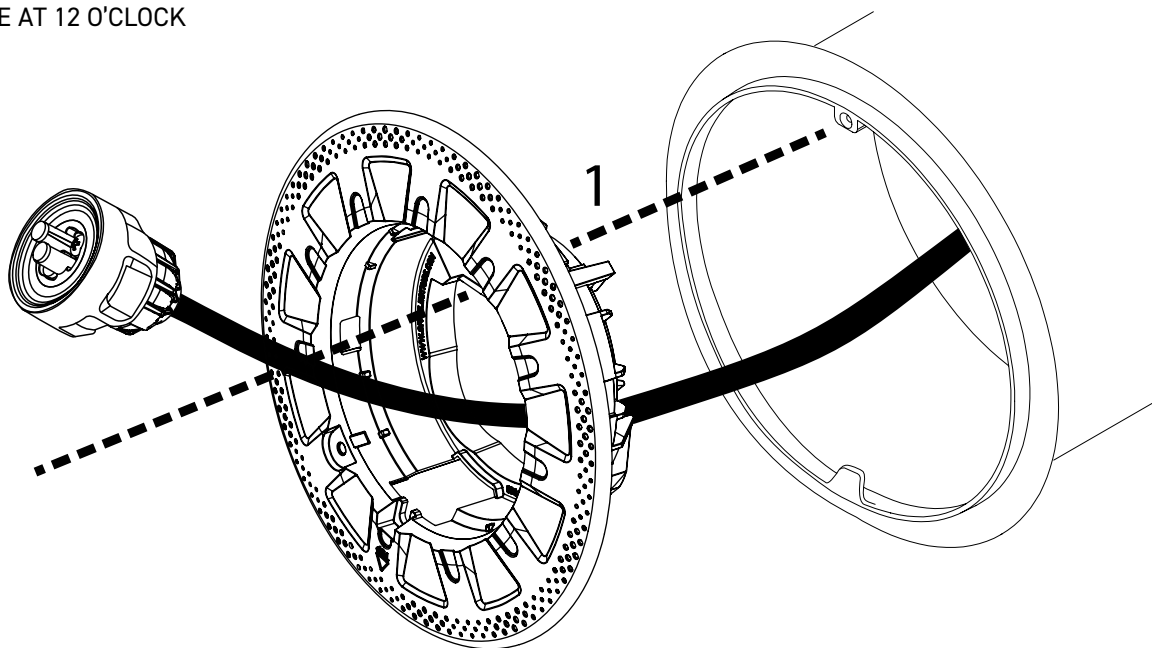

ENSURE CAM LOCKS FIT
INSIDE NICHE NEATLY

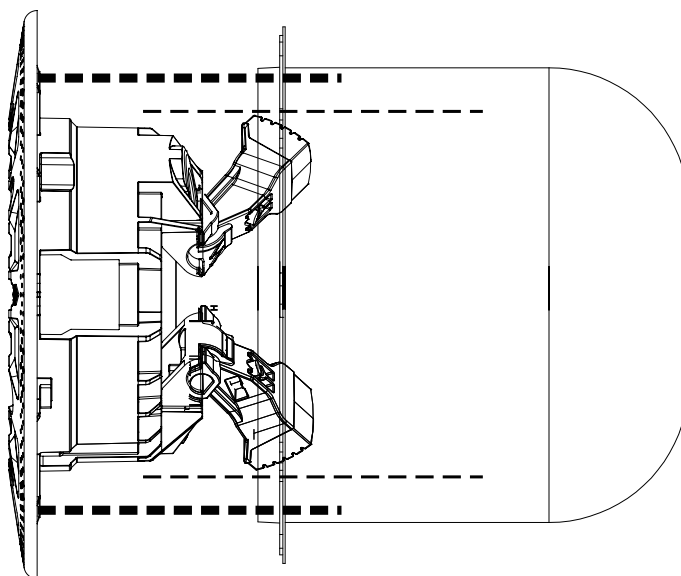

R6 RETRO FIT INSTRUCTIONS (CONT.)

PLACE BASE OF ADAPTOR TAB INTO THE NICHE TAB

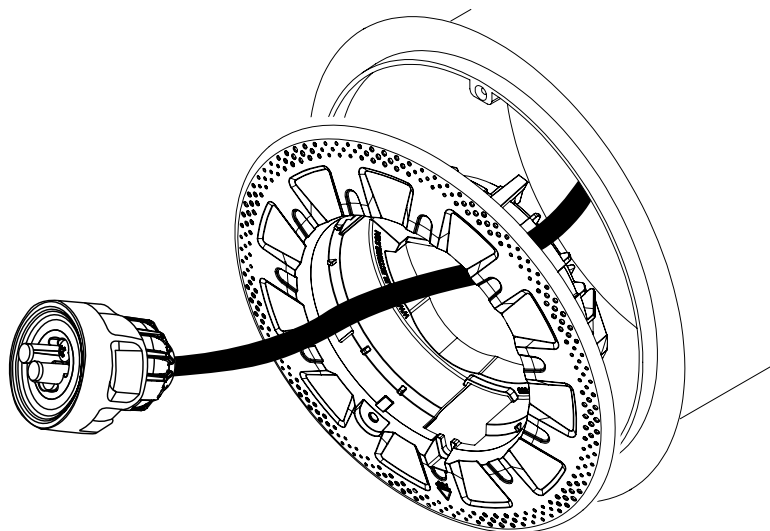

ENSURE THE ADAPTOR TAB SITS FIRMLY IN THE NICHE TAB

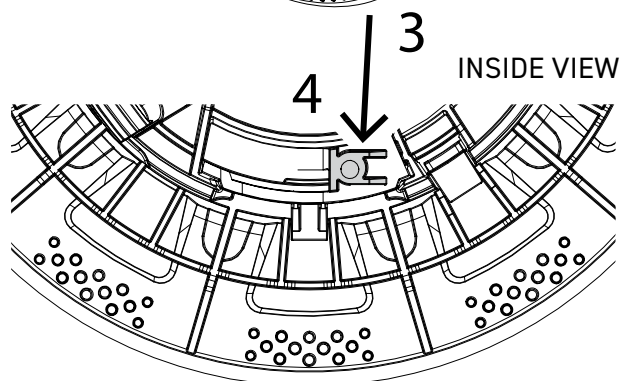

ALIGN THE TOP SCREW WITH THE SCREW HOLE INSIDE THE NICHE

USE A SCREWDRIVER TO FIX THE NICHE ADAPTOR TO THE NICHE USING THE MOUNTING SCREW

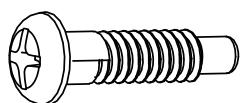

TIGHTEN THE LOWER SCREW IN THE ADAPTOR TAB
GO TO **SECTION C: CONNECT LUMINAIRE**

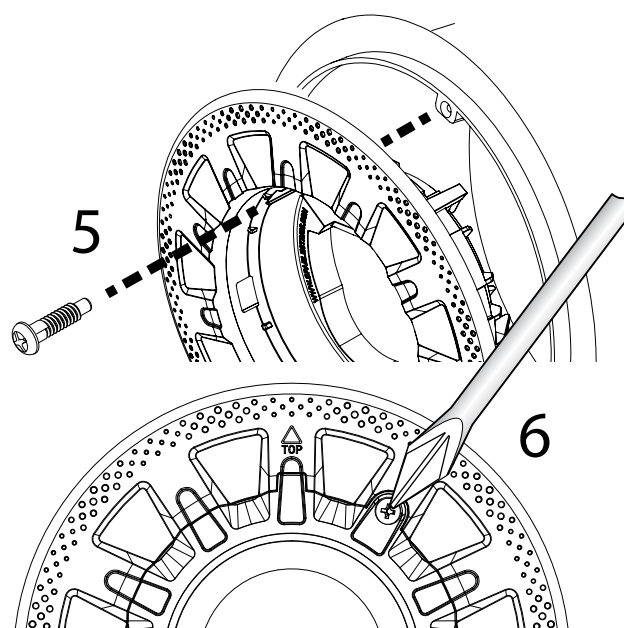

IF NICHE TAB & SCREW FITTING IS NOT INTACT:

CENTRE NICHE ADAPTOR INTO NICHE, SO THE SCREW HOLE IS AT 12 O'CLOCK, OR LINES UP WITH THE SCREW FITTING ON NICHE

ENSURE THE CAM LOCKS GO INTO THE NICHE EASILY

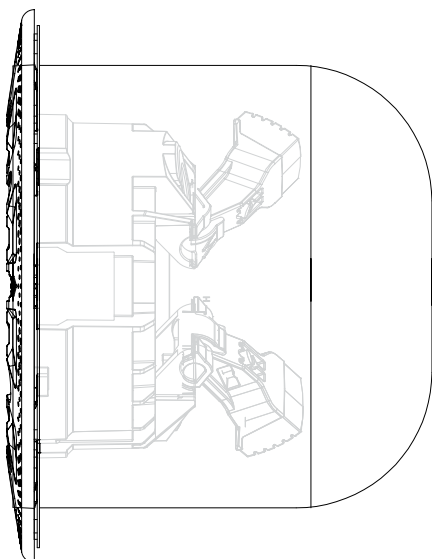
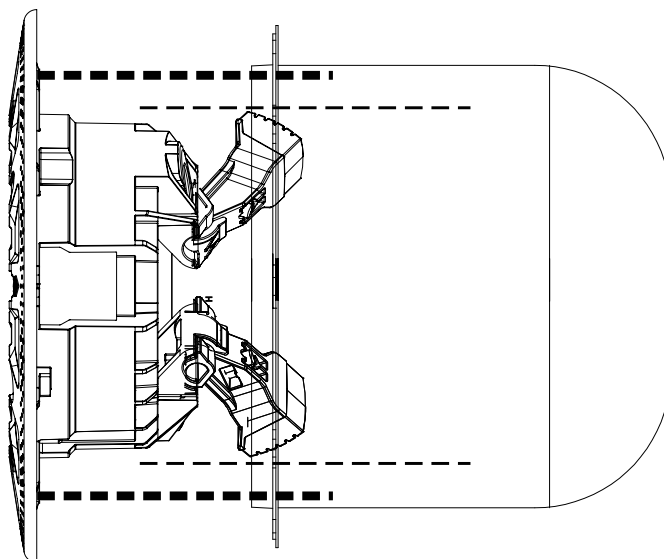

PUSH THE NICHE ADAPTOR INTO THE WALL SO IT SITS FLUSH AND IS FULLY INSERTED INTO THE NICHE

TIGHTEN THE TWO CAM LOCK SCREWS EQUALLY AND IN ROTATION, AS SHOWN, BY HAND UNTIL YOU FEEL THE NICHE ADAPTOR IS SECURE IN PLACE

DO NOT OVERTIGHTEN.

CHECK FOR SECURE FITTING, THE NICHE ADAPTOR SHOULD BE FIRM AND NOT ABLE TO MOVE EASILY BY HAND

GO TO **SECTION C: CONNECT LUMINAIRE**

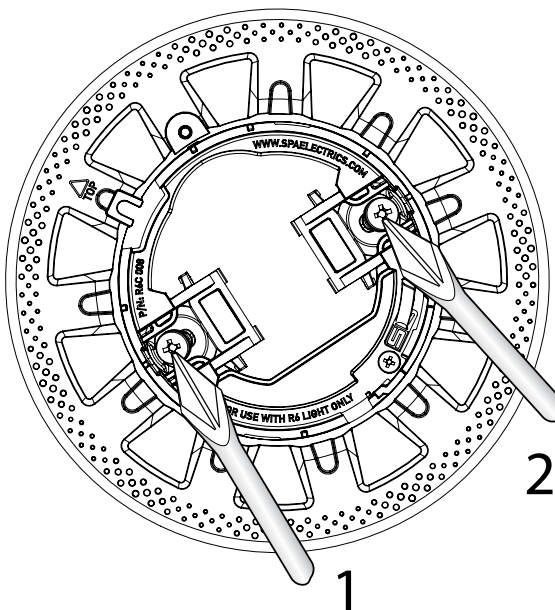

R6 RETRO FIT INSTRUCTIONS (CONT.)

[Click here for full instructions](#)

AS THE CAM LOCK SCREWS TIGHTEN, THE CAM LOCKS WILL MOVE IN AND UP, PULLING THE NICHE ADAPTOR FIRMLY INTO THE NICHE

MINIMUM CAM LOCK POSITION (LOOSE)

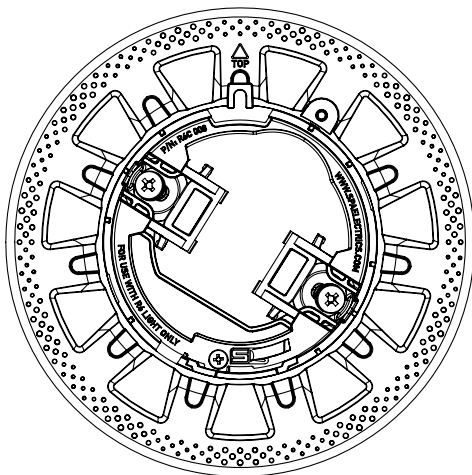

TIGHTEN SCREWS TO PULL NICHE ADAPTOR INTO NICHE

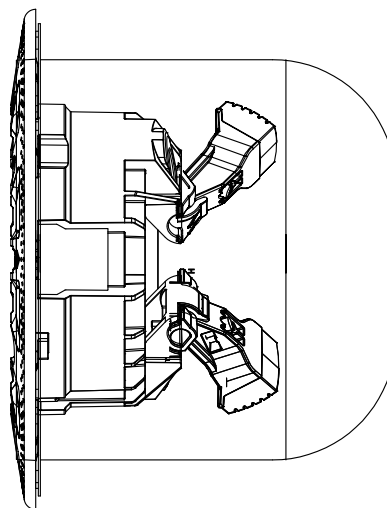

MAXIMUM CAM LOCK POSITION (TIGHT)

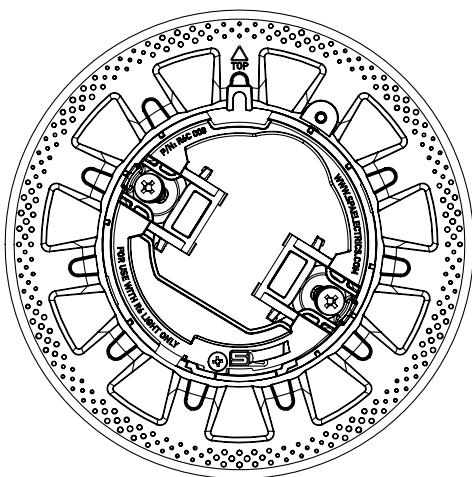

WHEN ALL CAM LOCKS ARE SCREWED TIGHT, THE CAM LOCKS SIT TIGHT AGAINST THE INSIDE OF THE NICHE, AND THE NICHE ADAPTOR IS PULLED FURTHER INTO THE WALL

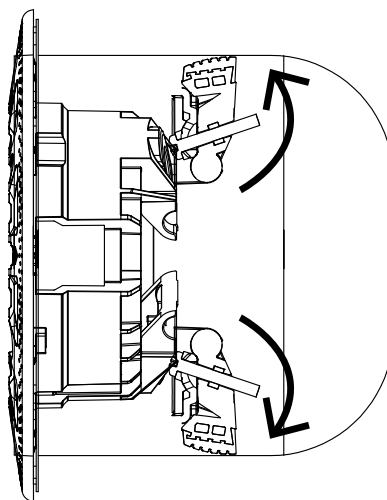

N1 RETRO FITS

N1 RETRO FITS WITH THREADED 1.5INCH FITTING BRACKET

Light Model	Dimension
Jandy WaterColors Nicheless LED lights (Unverified)	1.5" diameter 5 1/2" long
MicroBrite® Color and White LED Lights (Unverified)	1.5" fitting
BRIO LED Light 3" (Unverified)	1.5" return fitting
MINI-BRIO Mini LED Light (Unverified)	1.5" return fitting
SAVI Note LED Underwater Nicheless Pool Light (Unverified)	1-1.5" fitting
CMP Brilliant Wonders® 1.5" LED Light (Unverified)	1.5" fitting 4-4.5" depth
S.R Smith Micro LED Pool Light (only if the light fitting has not been removed)	1.5"PVC custom fitting which is supplied with the light



N1 RETRO FIT INSTRUCTIONS

ATTACH ADAPTOR:
FEED THE SPACER RING AND
ADAPTOR PLATE ONTO THE
CABLE AS SHOWN.

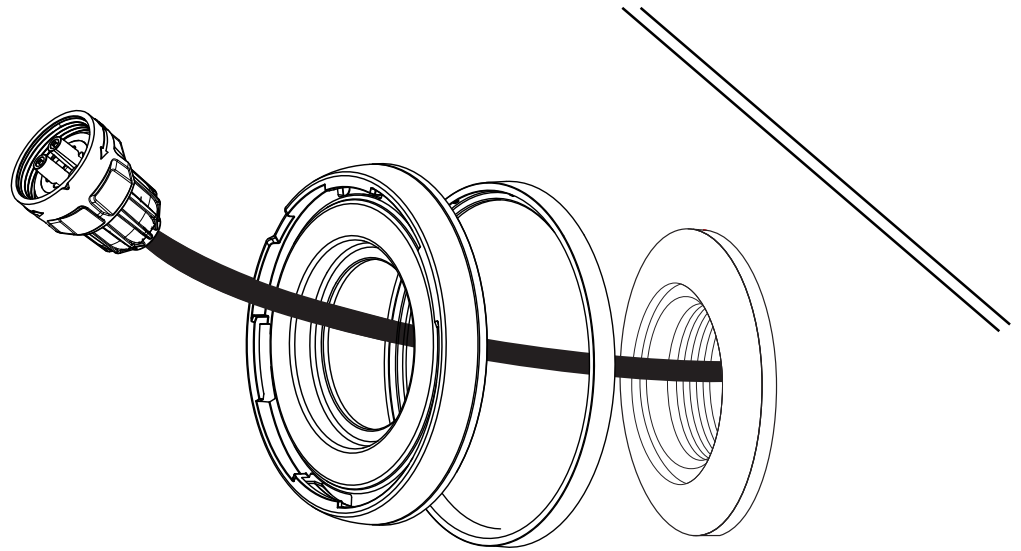

ATTACH THREADED COLLAR:
FEED THREADED COLLAR ONTO
ASSEMBLY AND THREAD INTO
COUPLING BY HAND.

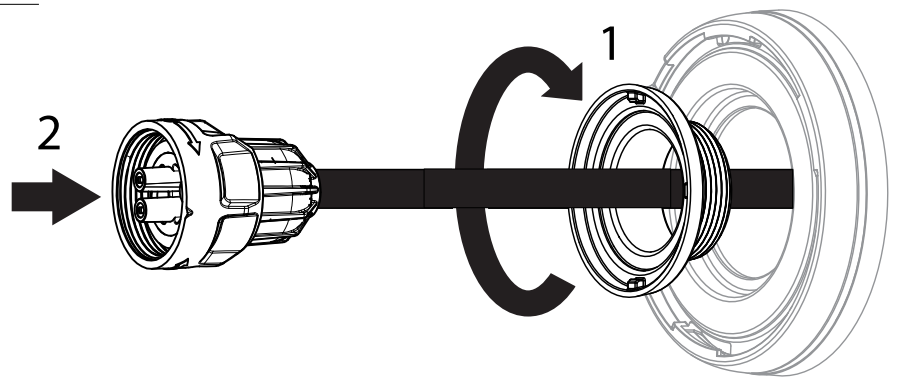

ADD ADAPTOR TOOL: ALIGN ADAPTOR TOOL WITH THREADED COLLAR ENSURING
THE CABLE IS PULLED THROUGH THE HOLE IN THE ADAPTOR TOOL

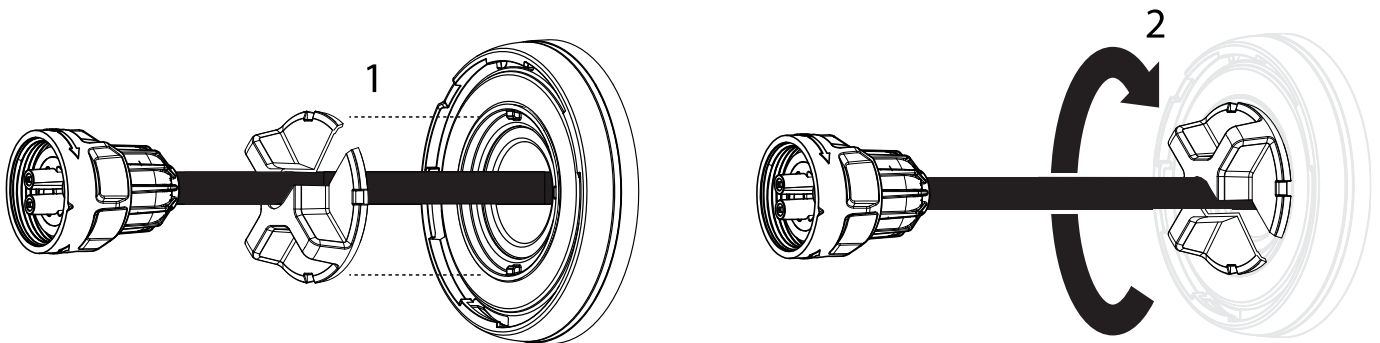

TIGHTEN FIRMLY BY HAND

REMOVE ADAPTOR TOOL AND STORE SAFELY

CABLE INSTALLATION

GLAND COLOR CODES

As pool lights are produced with varying cable sizes, every Spa Electrics Retro Series light comes supplied with a range of cable glands in order to correctly seal the cable entry point of the light. Choosing the correct size cable gland is very important so care should be taken when selecting a gland to ensure you are providing the best water seal possible.

Each Retro Series light is provided with up to 3 cable gland sizes. Each gland color represents a cable size and these colors and sizes are consistent across all Spa Electrics products, so regardless of which model lights you are installing the gland sizes will be the same for each.

GREEN



CABLE DIAMETER
35/64" (14mm) / 10 AWG

BLUE

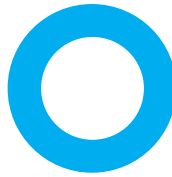

CABLE DIAMETER
13/32" (10.5mm) / 12 AWG

RED



CABLE DIAMETER
19/64" (7.6mm) / 18 AWG

CABLE FITMENT GUIDE

CABLE TOO SMALL

GAP BETWEEN
CABLE & GLAND

AND COLOR CODES

ool lights are produced with vary
e glands in order to correctly seal
ortant so care should be taken w

h Retro Series light is provided w
rs and sizes are consistent across

CABLE TOO LARGE

GLAND BULGING



izes, every Spa Electrics Retro S
entry point of the light. Choosin
ng a gland to ensure you are pro

cable gland sizes. Each gland col
lectrics products. so regardless

CORRECT

FIRM FITMENT
WITH NO BULGING



omes supplied with a range of
: size cable gland is very
:st water seal possible.

ts a cable size and these
del lights you are installin

CABLE STRIPPING GUIDE

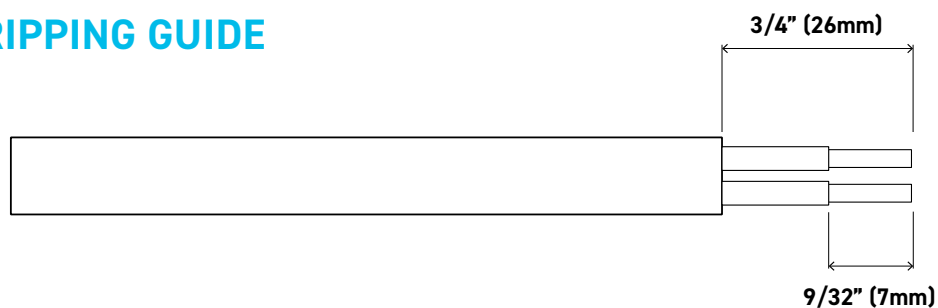

LED LIGHT OPERATION

OVERVIEW

The MULTI PLUS model can operate either via an LiYARD Controller or simply from your standard wall switch. By default, the MULTI PLUS light will come programmed for wall switch operation so no additional setup is required to operate in this mode. To operate the MULTI PLUS light via a wall switch, please follow the below steps.

Colors available are:

- | | | | |
|--------------------------|----------------------------|--------------------------------|-----------------------------------|
| 1. Daylight White | 4. Midnight Magenta | 7. Lagoon Green | 10. Show – Australian Dawn |
| 2. Tropical Aqua | 5. Rudy Red | 8. Show – Oceanic Views | 11. Show – Spring Equinox |
| 3. Electric Blue | 6. Spring Lime | 9. Show – Transcendence | |

OPERATING INSTRUCTIONS

1. To change the color of the light, simply turn your light **OFF** for **2 seconds** and then turn it back **ON**. This will signal the light to proceed to the next color in sequence. To select a desired color, simply step through the colors until you find your desired selection.
2. Your lights will automatically save your selected color once the power has been turned **OFF** for more than 1 minute. So the next time the lights are used, they will illuminate on the last color operated.
3. To reset or '**synchronize**' your lights; with the power turned **ON**, turn the power **OFF/ON** once rapidly. This will **RESET** your lights to **WHITE**.

SYNCHRONISED INSTALLATION

When installing multiple lights, to ensure synchronization and ease of operation ALL lights must operate from a single switch.

LiYARD Controller

For simpler installation and operation, the Spa Electrics LiYARD Controller can be easily fitted to any MULTI PLUS system.

For more information visit:
spaelectrics.com

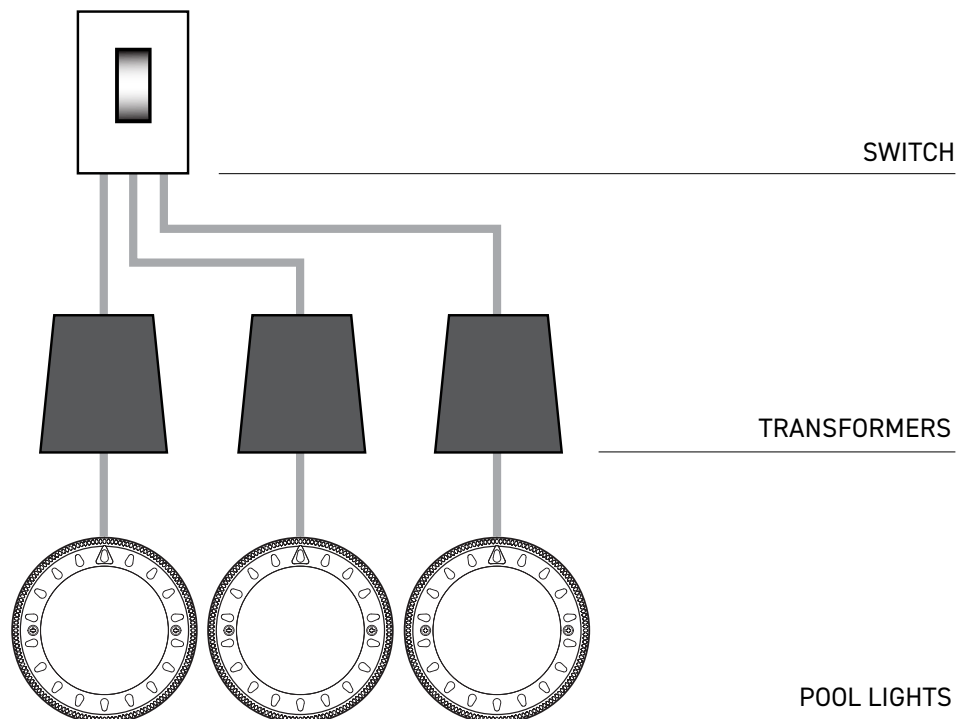

LED LIGHT OPERATION ADVANCED

SELECTING MODE OF OPERATION

The MULTI-PLUS light has 7 inbuilt modes of operation to allow operation on a variety of different control systems. When you first install your MULTI-PLUS light it will operate in the default, stand alone mode. In order to connect the light to a third party pool controller OR change to a different operating mode please follow the below steps.

STEP 1

If connecting to a pool automation system, please ensure the system is fully installed and you have completed all the relevant steps in the controller setup menu to operate the lights correctly. For more information on this please refer to the pool controller installation manual.

STEP 1A - CONTROLLER SETUP

During pool controller setup please select the light model at right to ensure correct operation.

AUTOMATION SYSTEM INSTALLED	SELECT LIGHT MODE
Spa Electric	-
Astral Connect 10/Connect Lite Plus/ Connect Lite*	SLX Light
Jandy Aqualink RS/Z4**	Jandy LED
Zodiac eXO iQ Chlorinator	Jandy LED
Pentair EasyTouch	Intellibrite Light
Pentair IntelliTouch	Intellibrite Light
Pentair IntelliCentre	Intellibrite Light
Hayward Omnilogic	Universal Colorlogic

If Installing Multiplus with a LITYARD transformer, please see LITYARD quick set up.

*Astral Connect 10/Connect Lite Plus/Connect Lite (2016 to current)
**Jandy Aqualink RS/Z4 (F/W Rev. 'R'-Current)

STEP 2

Ensure system has been off for 1 minute prior.

TURN LIGHTS **ON**

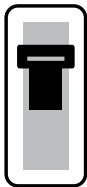

WAIT **1** SECOND

TURN LIGHTS **OFF**

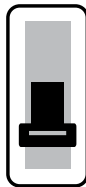

WAIT **14** SECONDS
(min 12s - max 17s)

TURN LIGHTS **ON**











[REPEAT
x 3]









NOTE: This step can either be performed via a wall switch OR via the controller panel/Mobile App.

LED LIGHT OPERATION ADVANCED

STEP 3

After 3 ON/OFF cycles the lights will FLASH RED. This is MODE 1 (Standalone mode). Turn the lights OFF/ON to progress to the next operating mode.

-  1. RED – Standalone Mode
-  2. GREEN – Spa Electrics Mode
-  3. MAGENTA – Connect10 Mode
-  4. WHITE – Intellibrite Mode
-  5. BLUE – Legacy Mode
-  6. YELLOW – Hayward Mode
-  7. PINK – P-TYPE Mode (legacy)
-  8. AQUA – Jandy Mode

AUTOMATION SYSTEM INSTALLED	SELECT LIGHT MODE	LIGHT SETUP COLOR
Spa Electric Mode	-	 GREEN
Astral Connect 10/Connect Lite Plus/ Connect Lite*	SLX Light	 MAGENTA
Pentair EasyTouch	Intellibrite Light	 WHITE
Pentair IntelliTouch	Intellibrite Light	 WHITE
Pentair IntelliCentre	Intellibrite Light	 WHITE
Hayward Omnilogic	Universal Colorlogic	 YELLOW
Jandy Aqualink RS/Z4**	Jandy LED	 AQUA
Multi Plus	Jandy LED	 AQUA

*Astral Connect 10/Connect Lite Plus/Connect Lite (2016 to current)
 **Jandy Aqualink RS/Z4 (F/W Rev. 'R'-Current)

STEP 4

Once the desired system is selected follow the steps to save the selection.

IMPORTANT: You must wait at least 35 seconds prior to turning the system back on OR selection process will fail and setup will need to be restarted.

TURN LIGHTS OFF

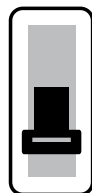

WAIT 35 SECONDS

TURN LIGHTS ON

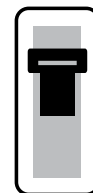









STEP 5













Your setup should now be complete. To confirm the system is working correctly, select a color and check to ensure the correct color is displayed.

LED LIGHT COMPATIBLE CONTROLLERS

OVERVIEW

-  1. RED – Standalone Mode / Wall Switchmode
-  2. GREEN – Spa Electrics Mode
-  3. MAGENTA – Connect10 Mode
-  4. WHITE – Intellibrite Mode
-  5. BLUE – Legacy Mode
-  6. YELLOW – Hayward Mode
-  7. PINK – P-TYPE Mode (legacy)
-  8. AQUA – Jandy Mode

CONTROLLERS / AUTOMATION SYSTEMS

AUTOMATION SYSTEM INSTALLED	SELECT LIGHT MODE	LIGHT SETUP COLOR
Spa Electric Mode	–	 GREEN
Astral Connect 10 (2016 to current)	SLX Light	 MAGENTA
Astral Connect Lite/+	SLX Light	 MAGENTA
Astral Connect Lite/+	Legacy Mode	 BLUE
Pentair EasyTouch	Intellibrite Light	 WHITE
Pentair IntelliTouch	Intellibrite Light	 WHITE
Pentair IntelliCentre	Intellibrite Light	 WHITE
Pentair Color Sync	Intellibrite Light	 WHITE
Hayward Omnilogic	Universal Colorlogic	 YELLOW
Jandy Aqualink RS/Z4 (F/W Rev. 'R'-Current)	Jandy LED	 AQUA
Multi Plus	Jandy LED	 AQUA
Hayward Omnihub	Universal Colorlogic	 YELLOW
Hayward Colorlogic	Universal Colorlogic	 YELLOW

LITYARD INSTALLATION

BEFORE YOU START

The Remote Handset is designed to be used with the Spa Electrics LiTYARD 2 Controller. (Please check product labeling to ensure it is suitable).

For Retro-fit installations, where existing transformers have been hardwired; a suitably qualified electrician must disconnect the transformers and terminate with a plug top connection in accordance with NEC and State Electrical Codes for hardwired installations.

WIRING EXAMPLE

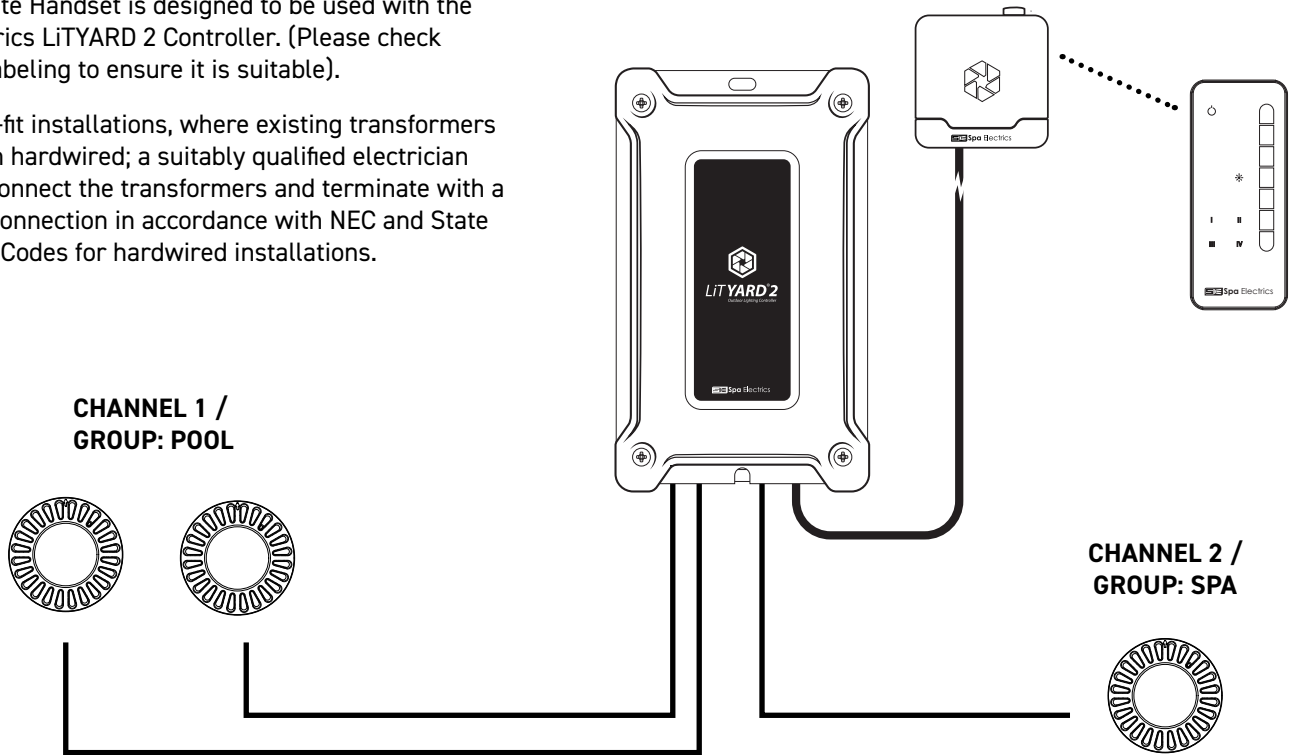

LITYARD 2 QUICK SETUP

The Remote Handset has a QUICK SETUP feature to program LiTYARD 2 for operation.

STEP 1: Ensure the lights have been **OFF** for a minimum of **30 seconds**, then turn the system **ON** using the Remote Handset.

STEP 2: Press the following static colors in order with a **1 second** pause between each press.

2a. WHITE

2b. RED

2c. GREEN

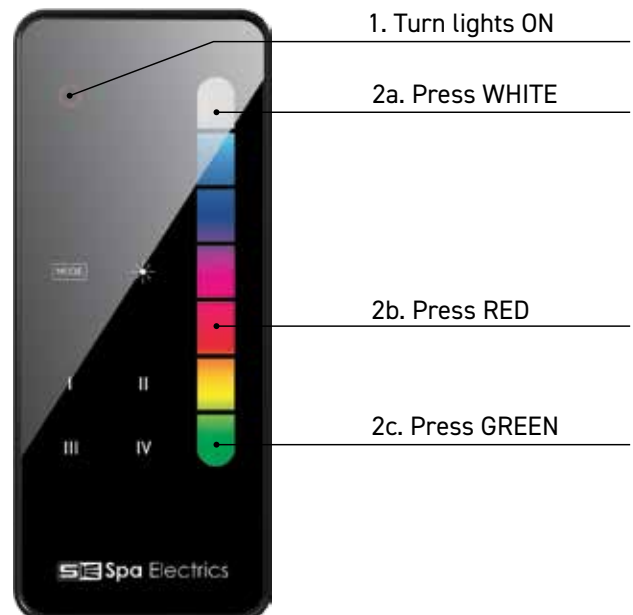

If performed correctly, the lights will illuminate **GREEN**. Confirm correct operation by selecting a different color using the Remote Handset.

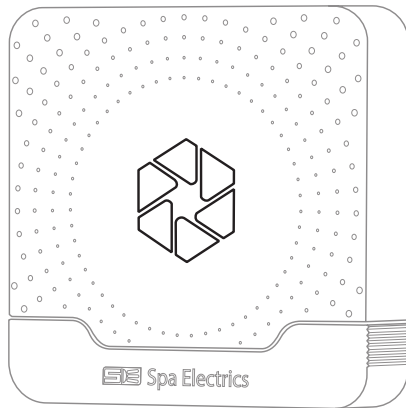

LITYARD RF BRIDGE LED STATUS

THE FRONT OF THE LITYARD RF BRIDGE HAS AN LED INDICATOR. PLEASE SEE BELOW FOR THE STATUS OF DIFFERENT COLORS INDICATED.



<p>SOLID GREEN</p> 	INDICATES THE LITYARD RF UNIT IS POWERED UP
<p>SOLID RED</p> 	INDICATES THE LITYARD RF BRIDGE IS READY FOR PAIRING TO A REMOTE HANDSET
<p>FLASHING RED</p> 	INDICATES THE LITYARD RF BRIDGE IS PAIRED TO A REMOTE HANDSET. FOLLOW "HANDSET PAIRING - MEMORY RESET" TO CONNECT A NEW HANDSET.

HANDSET PAIRING

Your Remote Handset should come pre-assigned to the LiYARD RF Bridge. However if it is not paired, please follow the below instructions:

STEP 1: Press the pairing button on the base of the LiYARD RF Bridge. The LiYARD RF Bridge will now switch to learning mode, indicated by the solid red LED.

STEP 2: Within 7 second, press any of the buttons on the Remote Handset. The Remote Handset is now assigned to the LiYARD RF Bridge.

MEMORY RESET: To reset the receiver memory, press and hold the button on the bottom of the LiYARD RF Bridge for 10 seconds. The LED indicator will flash fast initially, then flash slow indicating the memory has been erased. Once erased, release the Button and complete steps 1 & 2 to program the Remote Handset.

TO ACCESS THE PAIRING BUTTON ON THE LITYARD RF BRIDGE:

1. Slide down the Bottom cover of the LiYARD RF Bridge.

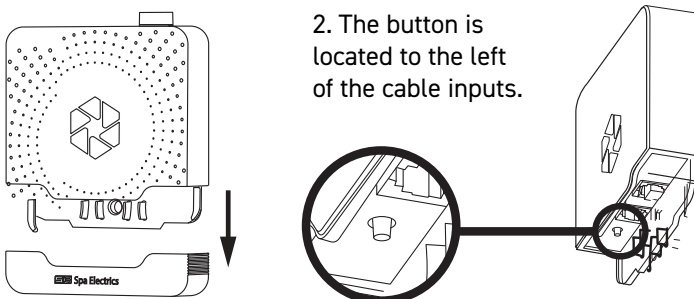

REMOTE HANDSET OPERATION

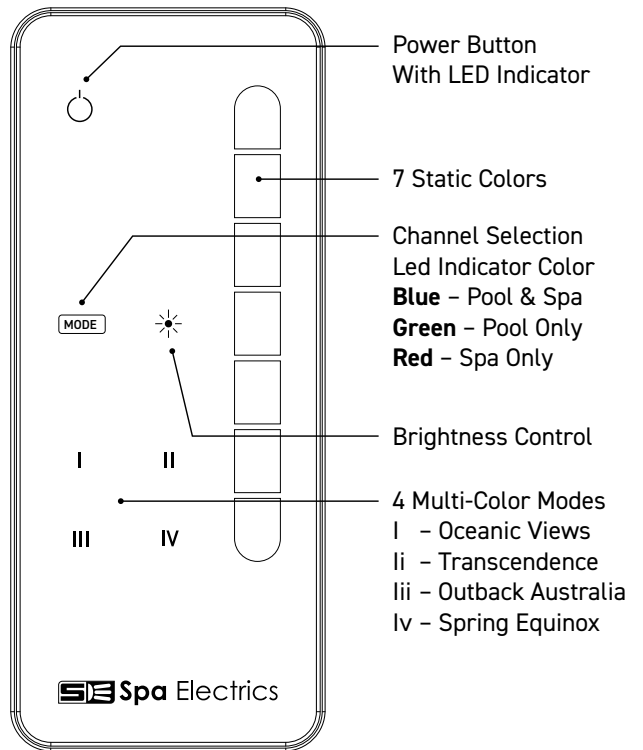

NOTE: AFTER 20 SECONDS OF INACTIVITY, THE REMOTE HANDSET WILL RETURN TO 'SLEEP MODE'.

QUICK SET UP JANDY CONTROLLER

QUICK SETUP – JANDY AQUALINK RS/Z4

NOTE: QUICK SETUP – JANDY AQUALINK RS/Z4 is only available with MULTI PLUS lights produced after serial number: EM-16942 or W9-19773

STAGE 1 – POOL CONTROLLER SETUP

When connecting the Multi Plus light to an Aqualink RS/Z4 pool controller please ensure the system is fully installed and you have completed all the relevant steps in the controller setup menu to operate the lights correctly.

During pool controller setup ensure that the light model selected is JANDY LED LIGHT

(For more information on this please refer to the pool controller installation manual)

NOTE: Some older pool controllers may not support these models. Please contact the controller manufacturer for upgrade assistance.

STAGE 2 – POOL LIGHT SETUP

Step 1 – Ensure the light has been turned off for at least 30 seconds.

Step 2 – From the home screen on the control panel, Select “Equipment ON/OFF”.

Step 3 – Select the channel for the lights, each channel will need to be setup individually.

Step 4 – Select DISCO TECH in the “Set Color” menu.

Step 5 – After the controller finishes power cycling, the Multi Plus light will turn itself off for 1.5 seconds and turn on DISCO TECH. This will indicate that the mode setup has been completed correctly.

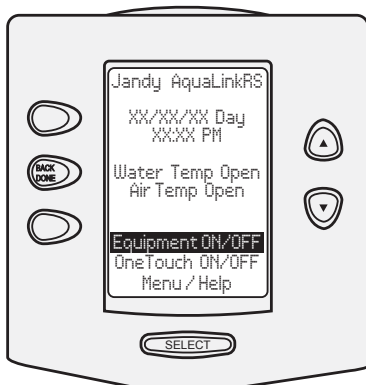

Step 2

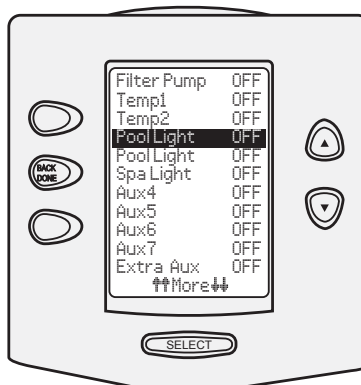

Step 3

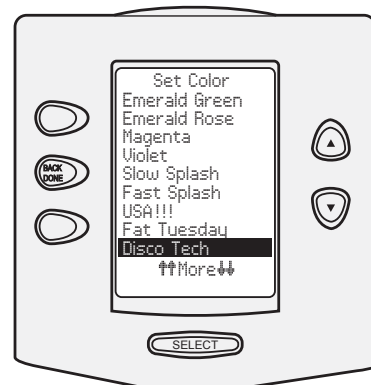

Step 4

QUICK SET UP INTELLIBRITE CONTROLLER

QUICK SETUP - INTELLITOUCH/EASYTOUCH

NOTE: QUICK SETUP - INTELLITOUCH/EASYTOUCH is only available with MULTI PLUS lights produced after serial number: EM-10756 or W9-16029

STAGE 1 - POOL CONTROLLER SETUP

When connecting the Multi Plus light to an Aqualink, Intelitouch or Easytouch pool controller please ensure the system is fully installed and you have completed all the relevant steps in the controller setup menu to operate the lights correctly.

During pool controller setup ensure that the light model selected is INTELLIBRITE LIGHT

(For more information on this please refer to the pool controller installation manual)

NOTE: Some older pool controllers may not support these models. Please contact the controller manufacturer for upgrade assistance.

STAGE 2 - POOL LIGHT SETUP

Step 1 - Ensure the light has been turned off for at least 30 seconds.

Step 2 - Navigate to the "Lights/Colors" menu on the pool controller Handset or Control Panel.

Step 3 - Select MAGENTA in the color menu, and wait until the relays finish operating.

Step 4 - Select GREEN in the color menu, and wait until the relays finish operating.

Step 5 - Select BLUE in the color menu, and wait until the relays finish operating.

Step 6 - After 3 seconds the Multi Plus light will turn itself off for 1.5 seconds and turn on BLUE. This will indicate that the mode setup has been completed correctly.

Note: Steps 3-5 must be performed within 5-90 seconds of the end of the previous Step

INTELLITOUCH/EASY TOUCH CONTROLLERS

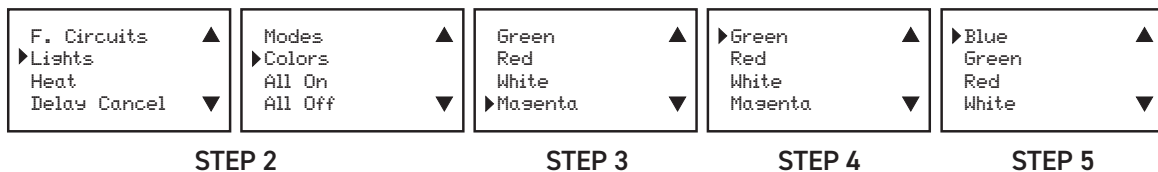

AQUALINK TRI CONTROLLERS

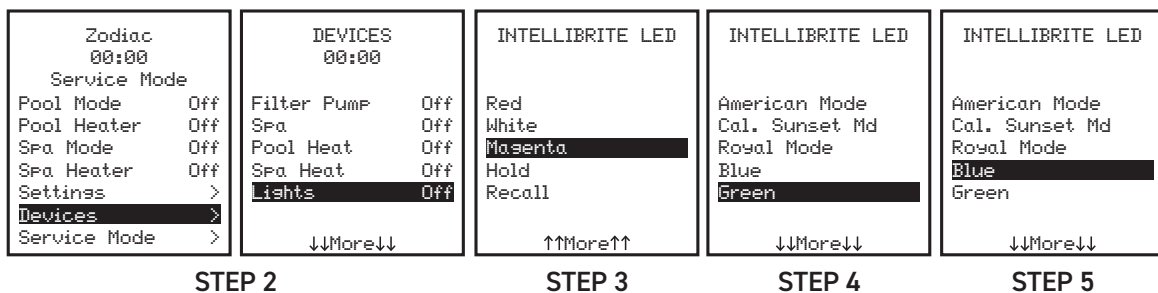

SERVICE & WARRANTY

TERMS OF TRADE

Notice to Customers

These Terms of Trade apply to the sale of Products to the customer (Customer) by Spa Electrics, Inc. (Spa Electrics).

Spa Electrics may alter these Terms of Trade should they deem necessary.

WARRANTY DETAILS

How to process a new warranty claim?

If you have a warranty claim please complete our online warranty submission form **via spaelectrics.com/warranty-submission** with all the requested information. Upon completion of this form, Spa Electrics will be in contact as soon as possible.

If you are unable to contact us via the website, or need a form, please email **techusa@spaelectrics.com** or contact us on **1-800-708-5545**.

All sales of Products by Spa Electrics to the Customer shall be on the following terms:

Orders

Orders may be given by telephone, fax or email and must include the preferred delivery date for the Products and collection or freight arrangements for the Products.

All Products shall be shipped CIF, Spa Electrics in Ringgold, Georgia (Facility).

Delivery

Spa Electrics shall ship the Products to the delivery address provided by the Customer, unless the Customer advises Spa Electrics that the Customer will arrange for pickup of the Products at the Spa Electrics Facility. Spa Electrics shall charge the Customer for shipping costs, unless otherwise agreed.

Price

The Customer shall pay Spa Electrics the price of the Products as set out in Spa Electrics' current (at the date of order) price book for the Customer as in effect at the date of order. Spa Electrics may at its discretion change the Customer's price book at any time by giving written notice to the Customer.

Payment

Unless Spa Electrics has approved in writing a credit limit for the Customer, and the amount owed by the Customer (including the price of the Products ordered) does not exceed that credit limit, payment for the Products shall be required prior to shipment to the Customer, using credit card.

Spa Electrics shall issue a statement of account to the Customer following the end of each calendar month. Where payment prior to shipment is not required by Spa Electrics, payment shall be due in cleared funds within thirty (30) days of the date of the statement of account, unless otherwise agreed.

If any amount remains unpaid for forty five (45) days from the account statement date, the Customer may be charged interest on at the rate of 9% per annum calculated daily on a compounding basis.

The Customer may be charged expenses incurred by Spa Electrics in relation to bad checks and collection services relating to overdue accounts, including but not limited to debt collection fees and legal costs.

Spa Electrics prefers payments via credit card or bank ACH (in cleared funds) to Spa Electrics' nominated bank account.

Risk and Title to Products

Title to the Products does not pass to the Customer until Spa Electrics receives full payment of the purchase price for those Products (in cleared funds and without deduction or set off) preferably using credit card or cleared bank funds.

Risk of loss or damage to the Products shall pass to the Customer upon shipment of the Products from date of shipment receipt, unless FOB terms are arranged by the Customer whereby risk will pass upon date of shipment.

Any claims for product damage or shortage are to be notified to Spa Electrics immediately upon receipt, or if shipped under FOB terms, with the freight company immediately upon receipt of goods.

MAP POLICY

Spa Electrics Inc has an established Minimum Advertised Price (MAP) Policy that an Authorized Reseller must follow for the advertising and marketing of our products. Please contact Spa Electrics if you require a copy of our MAP policy to become an authorized Spa Electrics reseller.

MAP pricing for all products will be provided upon the return of a signed agreement.

i. SPA Electrics MAP Policy Guidelines for Products

All advertised prices must be at or above MAP for all Spa Electrics, Inc., products.

Resellers are not required to list prices in advertising. If a price is listed in an advertisement, it must be at or above MAP. Other statements such as "call for price" or "call for quote" are acceptable and permitted. Resellers are also responsible for ensuring products are sold exclusively on the Resellers own website(s) and never cross sold any other website for any reason at any time.

Resellers are also responsible for ensuring their Spa Electrics, Inc., MAP pricing is at or above MAP on Internet search engines. Resellers are free to set the actual resale price of any product as long as it is at or above MAP price. Spa Electrics Inc, MAP policy for all products apply to advertising placements, including but not limited to: print ads (inserts, magazines, newspapers, catalogs, mail order catalogs, etc.), broadcast (radio and TV), direct mail, faxes, internet placement with third parties (banner ads, broadcast emails, destination pages, third-party sites), internet placements on resellers own website, & any flyers, posters or coupons.

ii. Pricing Statements

Spa Electric, Inc., Policy does allow resellers to omit pricing entirely from advertisements and/or advertisement statements such as "Call for Price" or "Call for Quote."

iii. Free Offers Associated with The SPA ELECTRICS, Inc., Product

Free shipping and/or handling, 0% sales tax, or free financing promotions do not violate the MAP.

iv. All The Spa Electrics, Inc., Products Price Matching Policies

Price matching policies are acceptable. Price matching cannot be used as a valid reason for violations of the Spa Electrics, Inc., MAP Policy. Advertised price must always be at MAP or higher.

v. Failure to Comply with the MAP Policy

At the sole discretion of Spa Electrics, Inc., failure to comply with MAP, intentional and/or repeated failure to abide, may result in the immediate loss of Authorized Reseller status & your ability to purchase all Spa Electrics, Inc., products both direct as well as through distribution.

vi. Spa Electrics, Inc., will utilize the following steps to resolve MAP violations:

1. Any and all dealers selling Spa Electrics, Inc., products which have not signed a Spa Electrics, Inc., MAP Policy agreement are classified as Unauthorized Resellers.
2. Distributors of Spa Electrics Inc products are required to provide a signed MAP agreement from any dealer selling Spa Electrics Inc products. Unauthorized dealers should not be sold to or provided a feed from any distributor whatsoever.
3. Violations from Authorized Resellers will need to be corrected within 24 hours of notification.

Thank you for your prompt attention to this matter, and your continued support of Spa Electrics.



LiTYARD 2[®]

Outdoor Lighting Controller



POOL & SPA

LIGHTING CONTROLLER

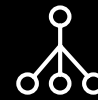

COMBINED POWER &
CONTROL FOR YOUR
**SPA ELECTRICS
MULTI PLUS LIGHTS**

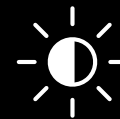

**COLOUR, SHOW
& BRIGHTNESS
CONTROL**



RF TECHNOLOGY
NO WIFI SETUP
COMPLICATIONS

SE Spa Electrics[®]

POOL & SPA CONTROLLER AVAILABLE NOW

LiYARD 2 allows for complete control of **MULTI PLUS LED** lights from the touch of a button, using the remote's sleek **iRIS** handset. The **LiYARD 2 Lighting Controller** provides power to your **External RF Bridge** ensuring **maximum range** and **reliable connectivity**. Control your lights independently or altogether with the controllers **2 zone** pool/spa channel function. With up to **54yd (164ft/50m) line of sight range**, controlling your lights has never been easier.

BUILT IN REMOTE AND 100W TRANSFORMER

Power & control for up to **6 Spa Electrics LED Lights**

SYSTEM STATUS

Easily check system operation and remote pairing function via the **LED status indicator**.

RF BRIDGE

External RF bridge ensures **connectivity** to the system in **challenging installations**. By allowing the bridge to be located in an accessible location.

COLOR SELECT

Choose between **7 static colors** & **4 color shows**.

POWER BUTTON

Power button on handset with **LED indicator** to identify channel status.

POOL/SPA CHANNEL SELECTION

Independently select the color of the pool and spa lights using the Mode selection button, with the **LiYARD's 2 zone capability**.

BRIGHTNESS CONTROL

Ability to dim individual outputs, select between **3 different levels of brightness**.

HANDHELD REMOTE

Capacitive touch screen, constructed from **premium materials** and **scratch resistant acrylic screen**.



SUITABLE FOR NEW AND EXISTING POOLS WITH SPA ELECTRICS MULTI PLUS LIGHTS

COULDN'T FIND THE LIGHT YOUR LOOKING FOR?

FOLLOW THESE SIMPLE STEPS

1

IMAGES

Take photos of your existing lights and transformer.

2

IDENTIFY

Use our Retro Series Replacement Guide to identify your existing lights and determine the correct replacement model.

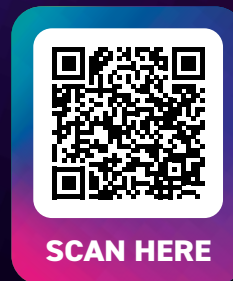

3

STILL CAN'T FIND IT

Call or email Spa Electrics Customer Support for assistance.

1800 708 5545 or techusa@spaelectrics.com